

Resources for Mothering Sunday

CHILDREN

Do

Appreciating mothers

15 mins **W**

Tell the story of a young monkey searching for his mother

You will need: a copy of *Monkey Puzzle* by Julia Donaldson, (optional) a toy monkey.

- Read aloud *Monkey Puzzle*, using the soft toy to help you.
- Ask the children: How do you think the monkey felt when he couldn't find his Mummy? What do you appreciate most about your Mum/Aunty/Grandma? What would you miss without them? If you were the monkey, how would you feel at the end of the story?
- You could link the story with Jesus' parable of the lost sheep, relating how the shepherd does not give up until he finds his lost sheep. Ask: If God is like a shepherd, how might he feel about each of us as his children?



Make

You deserve a cuppa

10 mins **E A**

Create a card for someone special

You will need: teacup template (see below), copied onto card, one per child, teabags, one per child, felt tips, scissors, sticky tape.

- Give everyone a teacup template to decorate and cut out.
- Encourage the children to write a thank you message to their Mum/Aunty/Grandma inside the card.
- Give everyone a teabag to attach to the opposite side of the card so the recipient can enjoy a rewarding cup of tea.
- If children are keen to help make the cup of tea, ensure they know that adult supervision is required.



YOUNG PEOPLE

Do

God's heart

10 mins **W S**

Think about mothers in different situations

You will need: a large red card heart, sticky notes, pens.

- Discuss the diversity of mothers and family situations that people find themselves in, e.g. new mums; mums-to-be; those who desperately want to be mums; step-mums; mums who foster or adopt; mums who are both mums and dads to their children; dads who are both mums and dads; mums who are in prison; mums whose children have died; mums whose children live far away; mums whose children are estranged from them; those whose mums or grandmas are very ill; those whose mums or grandmas are no longer with them.
- Invite the young people to write down on sticky notes each type of mother or family situation mentioned in the discussion.
- Invite them, one by one, to say, 'We pray for ...' and read out what is written on their sticky note, then place it inside the large heart as a symbol that God loves everyone, regardless of their family situation or relationships.
- Leave a few moments' silence between each prayer and finish with a corporate **Amen**.



Pray

Prayer cubes

10 mins **S**

A fun way to pray for your family

You will need: cube template copied onto card, one per child, felt tips, scissors, glue sticks.

- Give everyone a cube template and ask the young people to decorate each side of their cube with the name of someone in their family.
- They can then cut out and stick the prayer cube together.
- Invite everyone to practise rolling their cube and praying for the person whose name ends up on top.



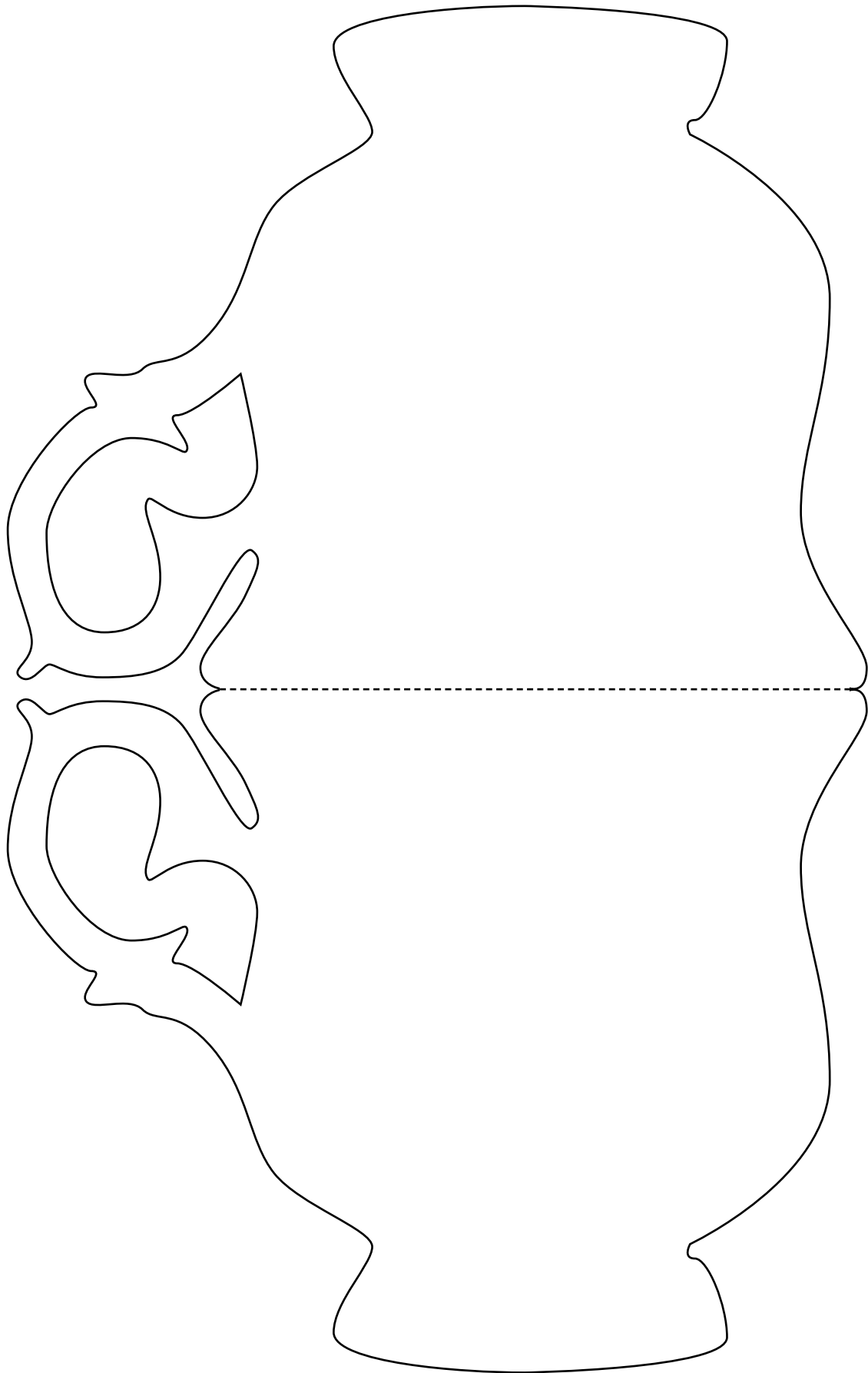

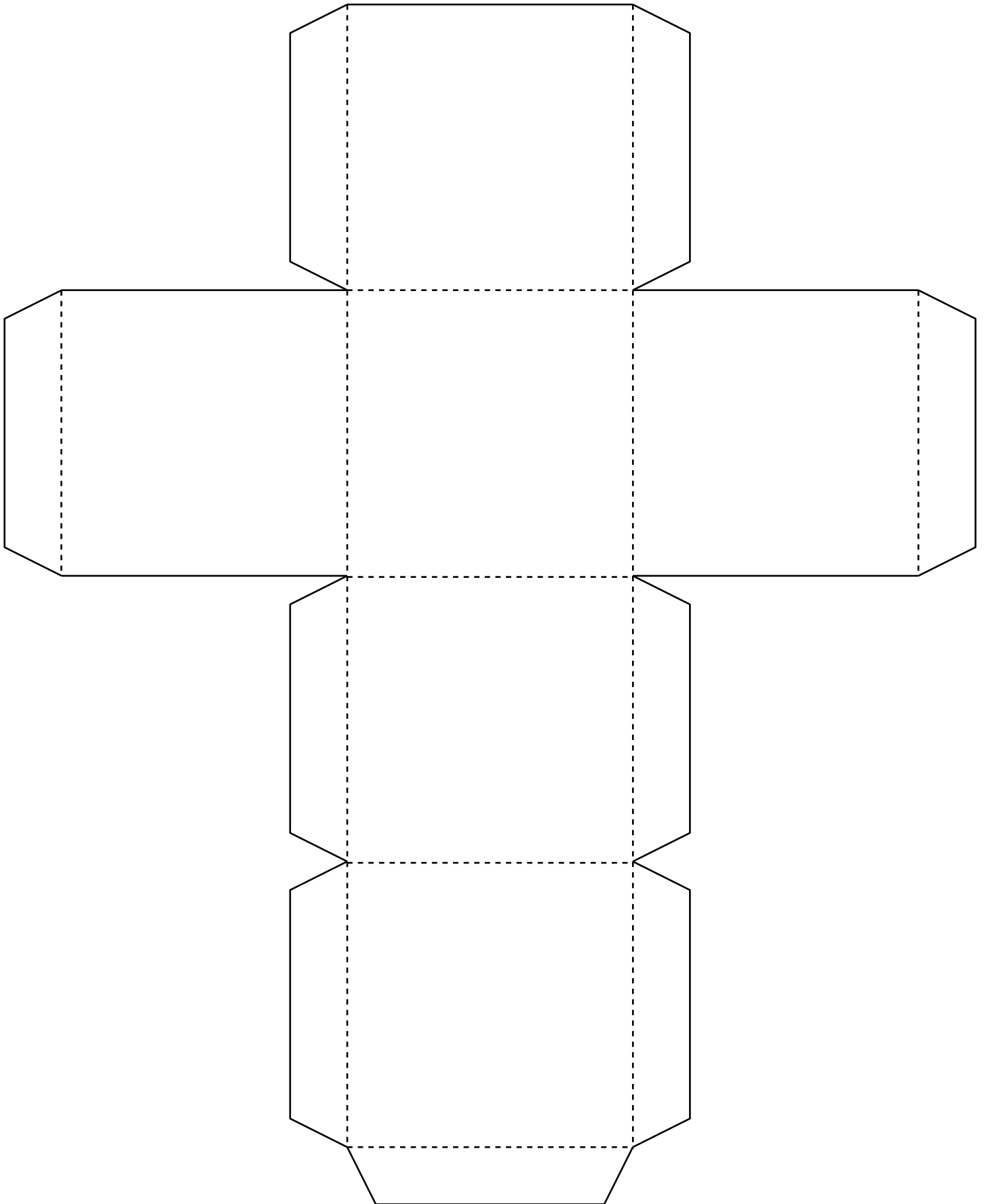

Resources for Mothering Sunday

ALL-AGE

Do

Watch *Brave*

15 mins **WES**

Use a film clip as a way into confession

You will need: DVD of Disney Pixar film *Brave* [PG]

- Show the film clip (start: 12:22; finish: 15:31) and talk about the relationship between Merida and her mother. Who do they think is in the right and who is in the wrong? How might they have acted in a similar situation? How might God resolve such a disagreement?
- Explain that because of Merida's desire to 'change her mother', Merida's mother is magically transformed into a bear. The rest of the film involves Merida trying to put right her mistake.
- Show a second clip from the lead up to the finale (start: 1:17:20; finish: 1:20:02). Talk about the transformation in the relationship between Merida and her mother. How have the dynamics changed? How might God feel about this?
- Lead into a time of private confession when the congregation can reflect on their own relationships with people they look up to. Close with some words of forgiveness.



Make

Felt flowers

10 mins **ES**

A visible celebration of mothering

You will need: paper straws, enough for one per person, different felt flower shapes and colours, colourful buttons, strong glue dots or PVA glue.

Mothering Sunday is not simply a day for mothers and grandmothers. Today we celebrate motherly qualities in those we admire, e.g. love, care, encouragement.

- Give everyone the opportunity to make a felt flower. Arrange and stick layers of different coloured and shaped petals on top of each other. Stick a button in the centre and attach a straw behind the flowerhead as a stalk.
- Invite people to swap their flowers with someone in the congregation whose motherly qualities they admire, or give their flower to someone they know outside church.

